

tend FLUORESCENT MACHINE LIGHT

TFL

FEATURES

- Tendered glass.
- IP67 protection.
- Osram PL Light.
- Service hour: 10,000hrs.
- Instantaneously started by Electronic Stabilizer.
- High Safety: fuse in the Electronic Stabilizer will be burnt immediately if any unusual situation happen.

MODEL DESIGNATION

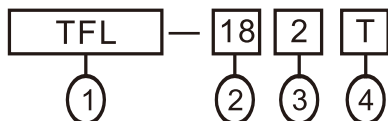

Designation	Signal	Description
1.Type	TFL	Fluorescent light
2.PL	18 36	18W 36W
3.Voltage	1 2 7 7D	120VAC 230VAC 24VAC 24VDC
4.Fix Type	Space T	Plastic base Steel Circle

LIGHT REPLACEMENT

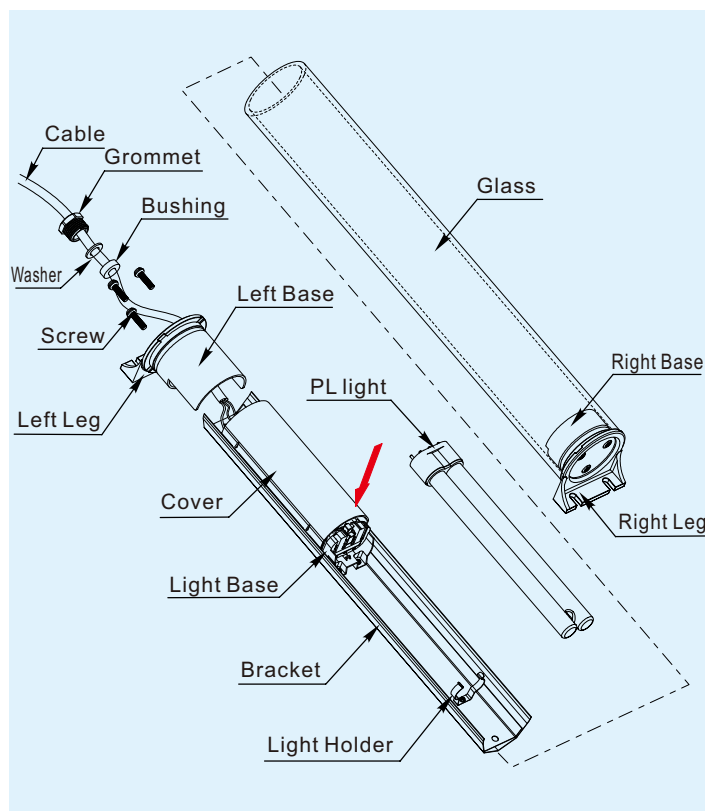

DIMENSIONS

TFL-18

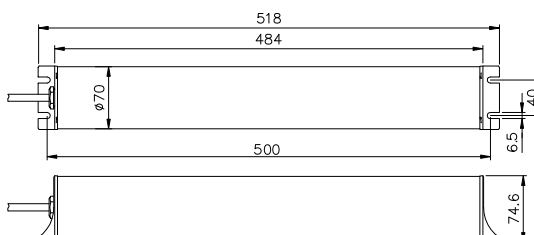
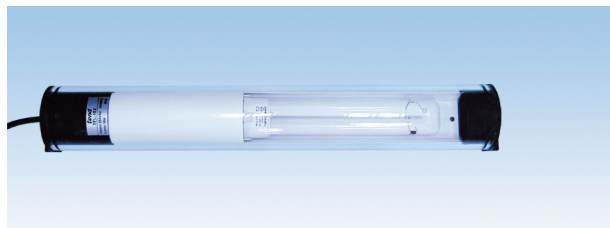

TFL-36

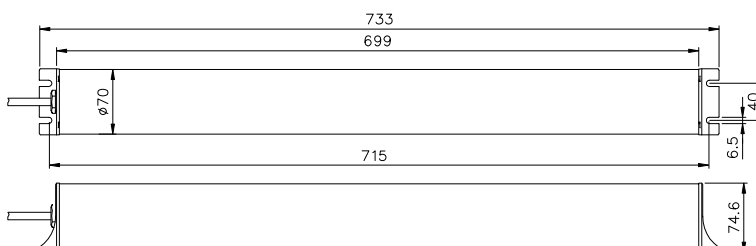
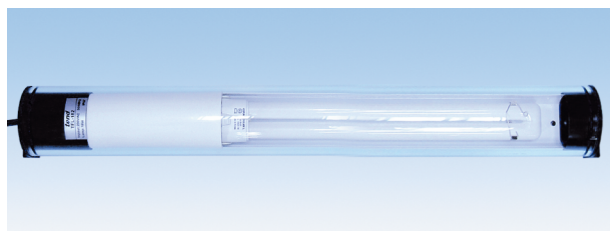

BASE DIMENSIONS

PLASTIC BASE

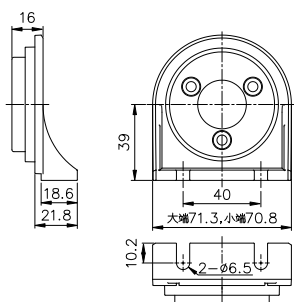

STEEL CIRCLE

